

NOTE:

For Knowing Act Application all activation devices must connect to the Purple wires from the OC-904 control (N.O. Dry Contact Only.)

Dipswitch Settings	OFF	ON
1. Safety Output	N.O.	N.C.
2. Stall Output	N.O.	N.C.
3. Auto / K.A.	Automatic	Knowing Act
4. Future Use		

Fully Automatic	Knowing Act
1. OFF	1. OFF
2. OFF	2. OFF
3. OFF	3. ON
4. OFF	4. OFF

INSTALLATION NOTES:

1. Set door speeds and verify proper door operation prior to final connection of sensor system.
2. Technician **MUST WALK TEST** to verify function and detection patterns comply with ANSI/BHMA A156.10 requirements.

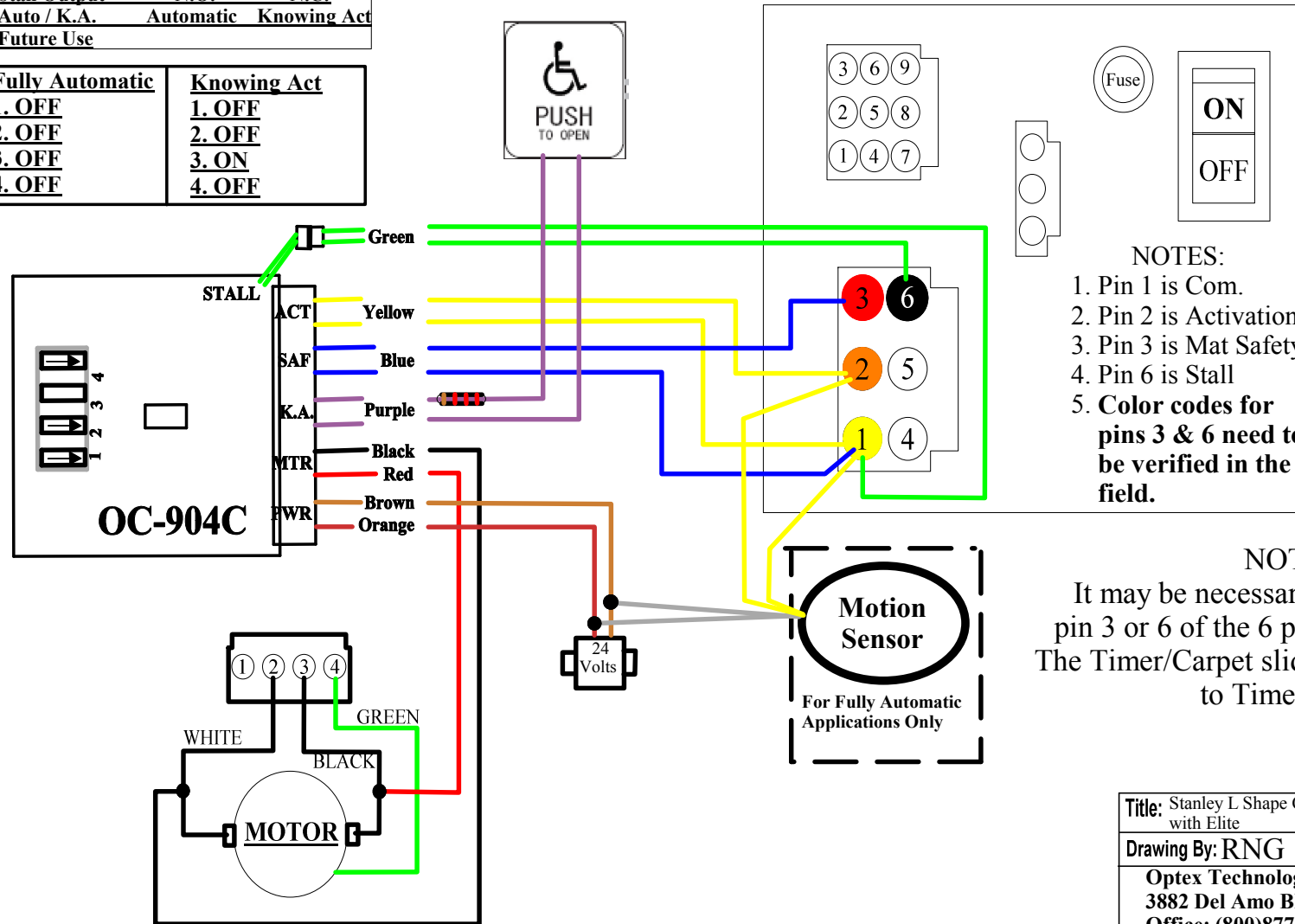

NOTES:

1. Pin 1 is Com.
2. Pin 2 is Activation
3. Pin 3 is Mat Safety
4. Pin 6 is Stall
5. **Color codes for pins 3 & 6 need to be verified in the field.**

NOTE:

It may be necessary to add a wire to pin 3 or 6 of the 6 pin molex connector. The Timer/Carpet slide switch must be set to Timer Logic.

Title: Stanley L Shape Control Single with Elite		Drawing # 01STALELI01
Drawing By: RNG	Date: 6/23/08	Sheet: 1 of 1
Optex Technologies Inc. 3882 Del Amo Blvd., Suite 604, Torrance, CA 90503 Office: (800)877-6656, Fax: (310)214-8655		